



VILLAGE OF EAST HILLS

INCORPORATED JUNE 24, 1931

209 Harbor Hill Road, East Hills, New York 11576
Telephone (516) 621-5600 · Fax (516) 625-8736

SAMPLE

HEIGHT SETBACK RATIO CALCULATIONS

Sample drawing for vertex calculations for height setback ratios:

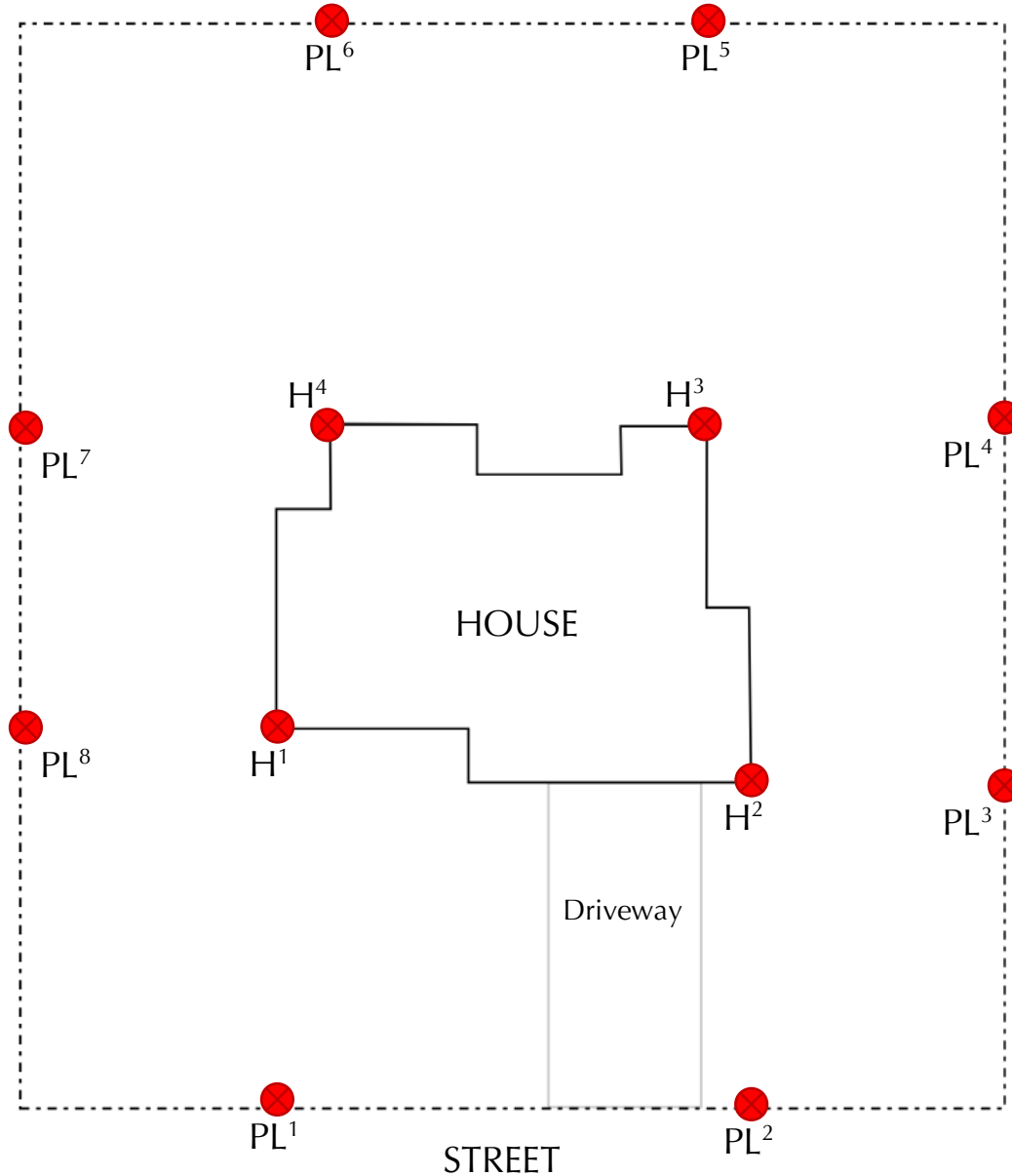

Vertex Calculations			
Front Yard Vertex:	$(H^1 + H^2 + PL^1 + PL^2)$	$\div 4$	$= \#$
Side Yard 1 Vertex:	$(H^2 + H^3 + PL^3 + PL^4)$	$\div 4$	$= \#$
Rear Yard Vertex:	$(H^3 + H^4 + PL^5 + PL^6)$	$\div 4$	$= \#$
Side Yard 2 Vertex:	$(H^1 + H^4 + PL^7 + PL^8)$	$\div 4$	$= \#$